

01-09



# **TOTAL CHAOS**

**FABRICATION**

[www.chaosfab.com](http://www.chaosfab.com)



**2009 Sales Catalog & Kit Specs**

# **HOT Products**

## **07+ Toyota FJ Cruiser/03+ Toyota 4Runner 2" Extended System**

PT# TCS-86002 Retail \$2750.00



## **07+ Tundra Long Travel System 2wd/4wd Up to 16" of Wheel Travel**

PT# TCS-87000 Retail \$3060.00



## **05+ Toyota Tacoma Prerunner/4WD 03+ 4Runner / 07+ FJ Cruiser Stock Lower Control Arm Skid Plates**

PT# TCA-86006 Retail \$125.00



## **07+ FJ Cruiser Complete Rear Link System Fully Adjustable Rear Link System**

PT# TCA-86400 Retail \$1289.00



## **07+ Toyota Tundra 2WD/4WD 08+ Toyota Landcruiser Uniball Upper Control Arm Uniball Upper Control Arm**

PT# TCS-87500

Retail \$755.00

PT# TCS-87504

Retail \$755.00



## **05+ Tacoma Prerunner 03+ 4Runner 2WD 3.5" Bolt-on Lift Spindles**

For stock or TOTAL CHAOS upper control arms

PT# TCA-86350

For TOTAL CHAOS long travel kit

PT# TCA-86350LT

Retail \$1399.00 pr.



## Table of Contents

Page 2	Hot Products
Page 3	Table of contents
Page 4	77500 – 2007+ Chevrolet Silverado 1500/GMC Sierra 1500 2WD & 4WD Upper Control Arm Kit
Page 5	80501 – 2004+ Ford F150 2WD & 4WD Upper Control Arm Kit
Page 6	86000 – 2005+ Tacoma Prerunner & 4WD / 07+ FJ Cruiser / 2003+ 4Runner +3.5" Long Travel Suspension
Page 7	86002 – 2007+ FJ Cruiser / 2003+ 4Runner +2" Long Travel Suspension
Page 8	87000 – 2007+ Toyota Tundra 2WD & 4WD Long Travel Suspension
Page 9	87500 – 2007+ Toyota Tundra 2WD & 4WD Upper Control Arm Kit
Page 10	87504 – 2008+ Toyota Landcruiser Upper Control Arm Kit
Page 11	88000 – 2005+ Tacoma 2WD 5-Lug Long Travel Suspension
Page 12	88500 – 2005+ Tacoma 2WD 5-Lug Upper Control Arm Kit
Page 13	90500 – 2004+ Nissan Titan 2WD & 4WD Upper Control Arm Kit
Page 14	91420 – 1998-2004 Frontier 4x2 Desert Runner & 1999-2004 Xterra 2WD Long Travel Suspension
Page 15	91440 – 1998-2004 Frontier 4WD & 1999-2004 Xterra 4WD Long Travel Suspension
Page 16	91500 – 2005+ Nissan Frontier 2WD & 4WD Upper Control Arm Kit
Page 17	92100 – 1984-1995 Pickup 2WD 5-Lug Balljoint Long Travel Suspension
Page 18	92200 – 1984-1995 Pickup 2WD 5-Lug Uniball Long Travel Suspension
Page 19	95000 – 1986-1995 Pickup 4WD 6-Lug / 1986-1995 4Runner Gen. I "Caddy" Long Travel Suspension
Page 20	95200 – 1986-1995 Pickup 4WD 6-Lug / 1986-1995 4Runner Gen. II "Caddy" Long Travel Suspension
Page 21	95301 – 1986-1995 Pickup 4WD 6-Lug / 1986-1995 4Runner Gen. III "Caddy" Long Travel Suspension
Page 22	96000 – 1996-2004 Tacoma Prerunner & 4WD / 1996-2002 4Runner Long Travel Suspension
Page 23	96500/97500 – 1996-2004 Tacoma Prerunner & 4WD / 2000-2006 Tundra Upper Control Kit
Page 24	96504 – 2005+ Tacoma Prerunner & 4WD / 07+ FJ Cruiser / 2003+ 4Runner Upper Control Kit
Page 25	97000 – 2000-2006 Tundra 2WD & 4WD / 2001-2007 Sequoia 2WD & 4WD Long Travel Suspension
Page 26	98000 – 1996-2004 Tacoma 2WD 5-Lug Long Travel Suspension
Page 27	84-95 Toyota 2WD Accessories
Page 28	86-95 Toyota 4WD Accessories
Page 29	2007+ Tundra / 2005+ Tacoma / 2007+ FJ Cruiser Accessories
Page 30	2005+ Tacoma Prerunner / 2003+ 4Runner 2WD Lift Spindles
Page 31	1998-2004 Nissan Frontier Accessories
Page 32	1996-2004 Tacoma & 2000-2006 Tundra Accessories
Page 33	1996-2004 Tacoma & 2000-2006 Tundra Accessories
Page 34	Rear Suspension Accessories
Page 35	Miscellaneous Accessories
Page 36	Long Travel Suspension Application Guide
Page 37	Upper Control Arm Suspension Application Guide



**TCS-77500**

07+ Chevrolet U.C.A.

2007+ SILVERADO/SIERRA AND TAHOE/YUKON 2WD & 4WD

**Kit Includes:**

UPPER A-ARMS

1" UNIBALLS & RETAINING CLIPS

TAPERED ADAPTER PIN

GREASE FITTINGS

BUSHINGS & INNER SLEEVES

STAINLESS 17-4 HI-MIS SPACERS

ABS WIRE RELOCATION TAB



**MSRP: \$755.00**

**TRAVEL:** Varies by shocks installed

**LIFT:** 2"(1)(2)

**TIRE:** Determined by lift installed

**WHEEL:** 17"

**KIT INSTALL:** 2hrs

**Additional Items Required for Installation:**

AFTERMARKET COILOVER SHOCKS OR SPACERS

**Recommended Shock / Spring Set-up:**

Shock Specs: ICON VEHICLE DYNAMICS, FOX, SWAY-A-WAY

**Applications Note:**

U.C.A. kit is 100% bolt on and requires no permanent modifications.  
Vehicle track width will not increase. These arms are stock length.  
Upper arms will work with other lift kits that retain stock upper arm.

**Accessories / Upgrades:**

**Superlube: Synthetic grease (3 o.z. container)**

MSRP: \$12.49

(1) Actual lift is determined by installing coilover shocks.

(2) Lift will vary by how much preload is set on the coil spring - 2.5" maximum lift over stock.



## F-150 U.C.A.

2004+ FORD F-150 2WD & 4WD

### TCS-80501

#### Kit Includes:

UPPER A-ARMS

1" UNIBALLS & RETAINING CLIPS

GRADE 8 HARDWARE

GREASE FITTINGS

BUSHINGS & INNER SLEEVES

STAINLESS 17-4 HI-MIS SPACERS

TAPERED SPINDLE ADAPTERS



**MSRP: \$745.00**

**TRAVEL: 9"**

**LIFT: 2.5"(1)(2)**

**TIRE: 35"**

**WHEEL: 17"(3)**

**KIT INSTALL: 2hrs**

#### Additional Items Required for Installation:

COILOVER SHOCKS

#### Recommended Shock / Spring Set-up:

Shock Specs: SWAY-A-WAY, FOX, KING & ICON VEHICLE DYNAMICS

#### Applications Note:

U.C.A. kit is 100% bolt on and requires no permanent modifications.

Vehicle track width will not increase. These arms are stock length.

Upper arms will work with other lift kits that retain stock upper arm.

#### Accessories / Upgrades:

**TCA-48502:** 3/4" lowering shackle

MSRP: \$185.00

**Superlube:** Synthetic grease (3 o.z. container)

MSRP: \$12.49

(1) Actual lift is determined by installing coilover shocks.

(2) Lift will vary by how much preload is set on the coil spring - 2.5" maximum lift over stock.

(3) All model trucks require different wheels than factory, wheels must have 4.5" back spacing or less.



- TCS-86000K** 05+ TACOMA PRERUNNER AND 4WD LT KIT - FOX/KING
- TCS-86000S** 05+ TACOMA PRERUNNER LT KIT - SWAY A WAY
- TCS-86004** 03+ 4RUNNER / 07+ FJ CRUISER 2WD AND 4WD LT KIT - FOX/KING  
2005+ TACOMA 4WD / PRERUNNER & 2003+ 4RUNNER 2WD / 4WD  
2007+ FJ CRUISER 2WD / 4WD

**Kit Includes:**

- UPPER A-ARMS W/ BUSHINGS & ZERK FITTINGS
- LOWER A-ARMS W/ BUSHINGS
- TIE-ROD EXTENSIONS
- PLATED A-ARM END WASHERS
- D.O.T. BRAIDED BRAKE LINES
- 1" UNIBALLS W/ RETAINING CLIPS
- BOLT-ON UPPER SHOCK MOUNTS
- LIMIT STRAPS W/ ADJUSTERS & MOUNTS
- GRADE 8 HARDWARE
- TAPERED SPINDLE ADAPTERS
- BUMP STOP SPACERS

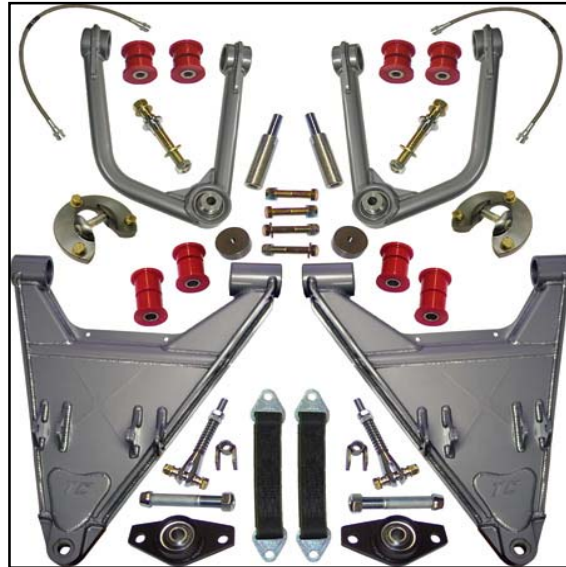

**MSRP: \$3060.00**

**TRAVEL: 13"    LIFT: 3-4"    TIRE: 285 (1)    TRACK INCREASE: 7"    KIT INSTALL: 8hrs**

**Additional Items Required For Installation:**

COILOVER SHOCKS, 4340 AXLES TO RETAIN 4WD(TCA-86300 / 86301), FIBERGLASS FENDERS

**Recommended Shock / Spring Set-up:**

4WD Shock Specs: Primary 8" travel 2.5" C/O FOX (98099-294A), SAW (56000-1004TCH), KING  
 4WD Shock Specs: Secondary 8" travel 2.5" FOX (98099-205TCF), SAW, KING  
 4WD Spring: 18" 3.0 600lb.\*  
 2WD Shock Specs: Primary 8" travel 2.5" FOX 98099-246B, KING, SAW. Secondary 8" travel 2.5" FOX, KING, SAW.  
 2WD Spring: 18" 3.0 500lb for KING / FOX. 16" 3.0 500lb for SAW.\*  
 ALL SHOCKS REQUIRE 1.25" WIDE SPACERS, 90DEG. RES. LINE FITTINGS, AND TAPERED LOWER COIL SEATS.  
 COILOVERS FOR 4WD VEHICLES MUST HAVE EXTENDED LENGTH LOWER ROD ENDS FOR AXLESHAFT CLEARANCE.

**Applications Note:**

Suspension travel varies on every vehicle. Welding is required to mount the limit strap mounts and bump stop spacers. This kit was not intended to use air bumps.

**Accessories / Upgrades:**

<b>TCA-86005:</b>	Bolt-on aluminum lower a-arm skidplate (pr)	MSRP: \$112.00
<b>TCA-86300:</b>	03+ 4Runner/FJ Cruiser 4340 custom extended axles (pr)	MSRP: \$575.00
<b>TCA-86301:</b>	05+ Tacoma 4340 custom extended axles (pr)	MSRP: \$575.00
<b>TCA-86350LT:</b>	3.5" Lift Spindles - 05+ Tacoma Prerunner & 2WD FJC/4Runner (pr)	MSRP: \$1399.00
<b>TCA-86600:</b>	Secondary shock hoop (8" travel 2.5" FOX / KING)	MSRP: \$250.00
<b>Superlube:</b>	Synthetic grease (3 o.z. container)	MSRP: \$12.49
<b>TCA-69700-NYL:</b>	Nylatron Bushing Kit	MSRP: \$257.00
<b>TCA-59698:</b>	Weld-on Spindle Gussets	MSRP: \$39.99

(1) Recommended tire sizes: 285/75R16 or 285/70R17, wheels need 4.5" of backspacing

\* Spring rates vary depending on other aftermarket accessories added.



TCS-86002

07+ FJ CRUISER / 03+ 4RUNNER 2" LONG TRAVEL KIT  
2007+ FJ CRUISER 2WD / 4WD & 2003+ 4RUNNER 2WD / 4WD

NO FIBERGLASS FENDERS REQUIRED! (FJ CRUISER ONLY)

**Kit Includes:**

- UPPER A-ARMS W/ BUSHINGS & ZERK FITTINGS
- LOWER A-ARMS W/ BUSHINGS
- TIE-ROD EXTENSIONS
- PLATED A-ARM END WASHERS
- D.O.T. BRAIDED BRAKE LINES
- 1" UNIBALLS W/ RETAINING CLIPS
- BOLT-ON UPPER SHOCK MOUNTS
- LIMIT STRAPS W/ ADJUSTERS & MOUNTS
- GRADE 8 HARDWARE
- TAPERED SPINDLE ADAPTERS
- BUMP STOP SPACERS
- WELD-ON RESERVOIR TABS



**MSRP: \$2750.00**

**TRAVEL: 11.5"    LIFT: 3-4"    TIRE: 285 (1)    TRACK INCREASE: 4"    KIT INSTALL: 8hrs**

**Additional Items Required For Installation:**

COILOVER SHOCKS, 4340 AXLES TO RETAIN 4WD

**Recommended Shock / Spring Set-up:**

2WD/4WD Shock Specs: Primary 8" travel 2.5" FOX, KING, SAW OR ICON (FOX PT#98099-294A) (SAW PT#56000-1004TCH)  
 2WD/ 4WD Spring: KING/ICON/SAW - 16" 3.0 600lb. - FOX - 18" 3.0 600lb.  
 (Bolt On Upper Shock Mounts are included with ICON & KING coil overs)

**Applications Note:**

Suspension travel varies on every vehicle. Welding is required to mount the limit strap mounts and bump stop spacers. This kit is designed to use a Rubber Bump Stop or the Light Racing FJ Specific Jounce bump stop.

**Accessories / Upgrades:**

<b>TCA-59698:</b>	Weld-on Spindle Gussets	MSRP: \$39.99
<b>TCA-86305:</b>	FJ Cruiser 4340 custom extended axles (pr)	MSRP: \$575.00
<b>TCA-86007:</b>	Bolt-on aluminum lower a-arm skidplate (pr)	MSRP: \$112.00
<b>TCA-69700-NYL:</b>	Nylatron Bushing Kit	MSRP: \$257.00
<b>Superlube:</b>	Synthetic grease (3 o.z. container)	MSRP: \$12.49

- (1) FJ Cruiser recommended tire sizes: 285/75R16 or 285/70R17 , wheels need 4.5" of backspacing
- (2) 4Runner recommended tire sizes: 275/75R16 or 275/70R17 , wheels need 4.5" of backspacing



**TCS-87000**

**07+ TUNDRA LONG TRAVEL**

2007+ TUNDRA 2WD / 4WD

**Kit Includes:**

- UPPER A-ARMS W/ BUSHINGS & ZERK FITTINGS
- LOWER A-ARMS W/ BUSHINGS
- TIE-ROD EXTENSIONS
- LOWER UNI-BALL CRADLES \*
- D.O.T. BRAIDED BRAKE LINES
- 1" UNIBALLS W/ RETAINING CLIPS
- BOLT-ON UPPER SHOCK MOUNTS
- LIMIT STRAPS W/ ADJUSTERS & MOUNTS
- GRADE 8 HARDWARE



**MSRP: \$3089.00**

**TRAVEL: 16" w/ 4WD    LIFT: 3-4"(2)    TIRE: 315/75(1)    TRACK INCREASE: 5"    KIT INSTALL: 10hrs**

**Additional Items Required For Installation:**

COILOVER SHOCKS, 4340 AXLES TO RETAIN 4WD, FIBERGLASS FENDERS

**Recommended Shock / Spring Set-up:**

2WD/4WD Shock Specs: Primary 8" travel 2.5" ICON Vehicle Dynamics C/O (PT# 5-9650), KING  
 2WD/4WD Secondary Shock Specs: ICON Vehicle Dynamics (PT# 25-0875-85), KING  
 2WD/ 4WD Spring: 18" x3.0" x 700lb.  
 (Bolt On Upper Shock Mounts are included with ICON & KING coil overs)

**Applications Note:**

Suspension travel varies on every vehicle. Welding is required to mount the limit strap mounts.  
 This kit is Not Designed For Use With Air Bumps

**Accessories / Upgrades:**

<b>TCA-87600:</b> Secondary Shock Hoops	MSRP: \$479.00
<b>TCA-87300:</b> Custom 4340 extended axles shafts and band clamps (pr)	MSRP: \$600.00
<b>TCA-59699:</b> Weld-on spindle gusset	MSRP: \$49.99
<b>TCA-87200:</b> 1" Front Differential Drop Spacer	MSRP: \$35.99
<b>Superlube:</b> Synthetic grease (3 o.z. container)	MSRP: \$12.49

- (1) Recommended tire size: 315/75R18, wheels need 4.5" of backspacing
- (2) Lift is determined by installation of aftermarket shock or spacer.
- (3) Wheel size varies by vehicle model. Tire size varies by lift installed.



**TCS-87500**

**07+ TUNDRA U.C.A.**

**2007+ TOYOTA TUNDRA 2WD / 4WD**

**Kit Includes:**

- UPPER A-ARMS W/ BUSHINGS
- PLATED END WASHERS
- 1" UNIBALLS W/ RETAINING CLIPS
- GRADE 8 HARDWARE
- GREASE FITTINGS
- TAPERED SPINDLE ADAPTERS
- ABS WIRE RELOCATION TAB



**MSRP: \$755.00**

**TRAVEL: 12"(1)    LIFT: 0-3"(2)    TIRE: See Below(3)    Kit Install: 2hrs.**

**Recommended Shock Set-up:**

Any aftermarket 2.5 coilover shock. U.C.A. kit is highly recommended with coilover or spacer lift to restore alignment.

**Applications Note:**

U.C.A. kit is 100% bolt on and requires no permanent modifications.  
 U.C.A. kit can be used with any other aftermarket lifts that retain factory upper a-arm.

**Accessories / Upgrades:**

<b>TCA-49704:</b> 3/4" Lift Shackles	MSRP: \$125.00
<b>TCA-87200:</b> 1" front differential drop spacer	MSRP: \$35.00
<b>TCA-59699:</b> Weld-on spindle gusset	MSRP: \$49.99
<b>Superlube:</b> Synthetic grease (3 o.z. container)	MSRP: \$12.49

- (1) Suspension travel varies on every vehicle and by brand of shock installed.
- (2) Lift is determined by installation of aftermarket shock or spacer.
- (3) Wheel size varies by vehicle model. Tire size varies by lift installed.

**TCS-87504****08+ LANCRUISER U.C.A.****2008+ TOYOTA LANDCRUISER****Kit Includes:**

UPPER A-ARMS W/ BUSHINGS  
PLATED END WASHERS  
1" UNIBALLS W/ RETAINING CLIPS  
GRADE 8 HARDWARE  
GREASE FITTINGS  
TAPERED SPINDLE ADAPTERS  
ABS WIRE RELOCATION TAB

**MSRP: \$755.00****TRAVEL: 12"(1) LIFT: 0-3"(2) TIRE: See Below(3) Kit Install: 2hrs.****Recommended Shock Set-up:**

Any aftermarket 2.5 coilover shock. U.C.A. kit is highly recommended with coilover or spacer lift to restore alignment.

**Applications Note:**

U.C.A. kit is 100% bolt on and requires no permanent modifications.  
U.C.A. kit can be used with any other aftermarket lifts that retain factory upper a-arm.

**Accessories / Upgrades:****Superlube:** Synthetic grease (3 o.z. container) MSRP: \$12.49

- (1) Suspension travel varies on every vehicle and by brand of shock installed.
- (2) Lift is determined by installation of aftermarket shock or spacer.
- (3) Wheel size varies by vehicle model. Tire size varies by lift installed.



## 05+ TAQUITO LONG TRAVEL KIT

**TCS-88000F**

05+ TOYOTA TACOMA 2WD 5-LUG LT KIT - FOX SHOCKS

**TCS-88000S**

05+ TOYOTA TACOMA 2WD 5-LUG LT KIT - SWAY-A-WAY SHOCKS

### Kit Includes:

UPPER A-ARMS W/ BUSHINGS & ZERK FITTINGS

LOWER A-ARMS W/ BUSHINGS

TIE-ROD EXTENSIONS

3/4" HEIMED OUTER TIE-ROD

D.O.T. BRAIDED BRAKE LINES

1" UNIBALLS W/ RETAINING CLIPS

BOLT-ON UPPER SHOCK MOUNTS

LIMIT STRAPS W/ ADJUSTERS & MOUNTS

GRADE 8 HARDWARE

TAPERED SPINDLE ADAPTERS

BUMP STOP SPACERS

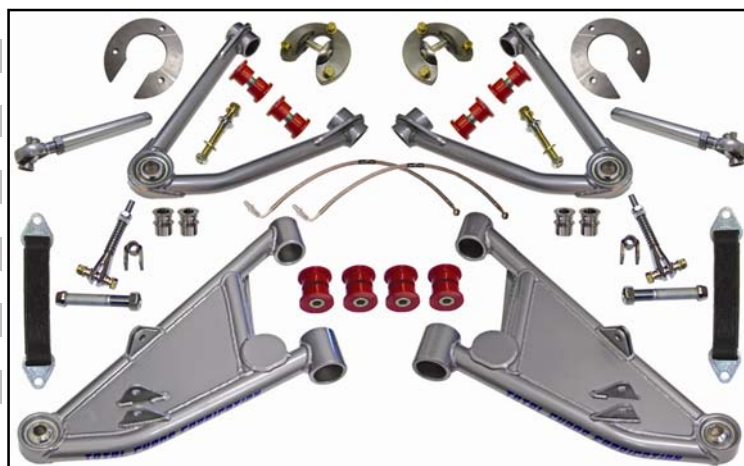

**MSRP: \$2999.00**

**TRAVEL: 13"    LIFT: 3-4"    TIRE: 33" MAX    TRACK INCREASE: 7"    KIT INSTALL: 10hrs**

### Additional Items Required For Installation:

COILOVER SHOCKS, FIBERGLASS FENDERS

### Recommended Shock / Spring Set-up:

FOX: PT# 98099-246B

SAW: PT# 56000-108 & 56107-100

Coil Spring: 16" 3.0 600lb.

ALL SHOCKS REQUIRE 1.25" WIDE SPACERS, 90DEG. RES. LINE FITTINGS, AND TAPERED LOWER COIL SEATS.

### Applications Note:

Suspension travel varies on every vehicle. Welding is required to mount the limit strap mounts and bump stop spacers.

This kit was not intended to use air bumps.

Some grinding on the caliper may be necessary for aftermarket wheel clearance.

**TCS-88500**

05+ TAQUITO U.C.A.

2005+ TACOMA MINI 5 LUG

**Kit Includes:**

- UPPER A-ARMS W/ BUSHINGS
- SHOCK CIRCLES
- 1" UNIBALLS W/ RETAINING CLIPS
- GRADE 8 HARDWARE
- GREASE FITTINGS
- TAPERED SPINDLE ADAPTER
- BRAKELINE RETENTION TAB & SPRING
- BUMPSTOP PATCH PLATE

**MSRP: \$745.00****TRAVEL: 8"      LIFT: 0-3"      TIRE: 31 x 10.50R15 (1)      Kit Install: 3hrs.****Recommended Shock Set-up:**

Sway A Way specific 2.5" coilover w/ Reservoir Part # SAW-56000-108-23 (Reservoir Bracket Part # TCA-88510)  
Sway A Way specific 2.5" coilover Non-Res. Part # SAW-56000-108-21

**Applications Note:**

Factory bump stop pad (located on frame) must be modified to install the 2.5" diameter coilover. A TC weld-on plate is supplied. Cutting and welding are required to perform this modification.  
Customers using external reservoir coilovers require TC accessory pt # TCA-88510 to mount reservoirs to factory shock bucket. Removal of factory anti-swaybar is required.

**Accessories / Upgrades:**

<b>Superlube:</b> Synthetic grease (3 o.z. container)	MSRP: \$12.49
<b>Reservoir Mounting Brackets:</b> TCA-88510	MSRP: \$64.50 pr

(1) Caliper may need to be cleared to fit aftermarket wheels.



## TITAN U.C.A.

**TCS-90500**

2004-2008 NISSAN TITAN 2WD / 4WD

**Kit Includes:**

UPPER A-ARMS W/ BUSHINGS  
1" UNIBALLS W/ RETAINING CLIPS  
GRADE 8 HARDWARE  
GREASE FITTINGS  
TAPERED SPINDLE ADAPTER

**MSRP: \$680.00****TRAVEL: 7"(1)****LIFT: 0-3.5"(2)****TIRE: 305/70R17****Kit Install: 2hrs****Recommended Shock Set-up:**

Any aftermarket coilover shock or spacer.  
Sway-A-Way 1" extended coilover will allow for additional wheel travel.

**Applications Note:**

U.C.A. kit is 100% bolt on and requires no permanent modifications.  
U.C.A. kit can be used with any other aftermarket lifts that retain factory upper a-arm.

**Accessories / Upgrades:****TCA-49504:** Titan 3/4" lowering shackle (pr) MSRP: \$185.00**Superlube:** Synthetic grease (3 o.z. container) MSRP: \$12.49

(1) Sway-A-Way PT# 56000-109-2 will allow 2" of additional droop travel. Clearance of coil bucket is required.

(2) Lift is determined by installation of aftermarket shock or spacer.



## TCS-91420\*

## FRONTIER 4X2 LONG TRAVEL KIT

98-04 NISSAN FRONTIER 4X2 CREW CAB / DESERT RUNNER & 2WD XTERRA

### Kit Includes:

- UPPER A-ARMS W/ BUSHINGS
- LOWER A-ARMS W/ BUSHINGS
- 1" UNIBALLS W/ RETAINING CLIPS
- CHROMOLY TIE RODS
- 3/4" CHROMOLY ROD ENDS
- D.O.T. BRAIDED BRAKE LINES
- URETHANE BUMP STOPS
- 2 1/2" LIFT SPINDLE - CORE CHARGE REQ.(1)
- GRADE 8 HARDWARE



**MSRP: \$3120.00**

**TRAVEL: 13" LIFT: 4-6" TIRE: 33x10.5 KIT INSTALL: 10+hrs TRACK INCREASE: 6"**

### Additional Items Required for Installation:

COILOVER SHOCKS, FIBERGLASS FENDERS, UPPER SHOCK HOOPS (TCA-91600)

### Recommended Shock / Spring Set-up:

Shock Specs: 8" travel 2.5" FOX(3), KING(4), or SWAY-A-WAY(5).

Spring: 18" 3.0 450lb-500lb for KING / FOX. 16" 3.0 450lb-500lb for S-A-W.

### Applications Note:

Suspension travel varies on every vehicle.

Cutting and welding are required to install kit.

This system is a coilover conversion only, kit eliminates torsion bars.

### Accessories / Upgrades:

<b>TCA-30010:</b>	Limit strap & adjustable clevis kit	MSRP: \$182.35
<b>TCA-91131:</b>	Idler arm brace	MSRP: \$33.74
<b>TCA-91600:</b>	Pre-bent shock hoop for 8" travel 2.5" shock	MSRP: \$250.00
<b>TCA-91698:</b>	Nissan king kong steering kit(6)	MSRP: \$695.00
<b>Superlube:</b>	Synthetic grease (3 o.z. container)	MSRP: \$12.49

(1) Spindle core charge of \$400.00 is required. Core consists of left and right spindles.

(2) All wheels require 3 3/4" backspacing to clear steering arm on spindle.

(3) For FOX 8" travel 2.5" shock, must use shock PT#980-99-246B.

(4) For KING 8" travel 2.5", shock must have 90 degree fitting coming out of the shock to the remote reservoir.

(5) For S-A-W 8" travel 2.5" shock, must use shock PT#56000-108 & coilover kit PT#56107-100.

(6) Pitman arm core charge of \$75.00 must be applied. PT#91131 Idler Arm Brace is included with King Kong Steering.



## TCS-91440

## FRONTIER 4X4 LONG TRAVEL KIT

1998-2004 NISSAN FRONTIER 4WD & 1999-2004 XTERRA 4WD

### Kit Includes:

- UPPER A-ARMS W/ BUSHINGS
- LOWER A-ARMS W/ BUSHINGS
- 1" UNIBALLS W/ RETAINING CLIPS
- CHROMOLY TIE RODS
- D.O.T. BRAIDED BRAKE LINES
- URETHANE DROOP STOPS
- GRADE 8 HARDWARE

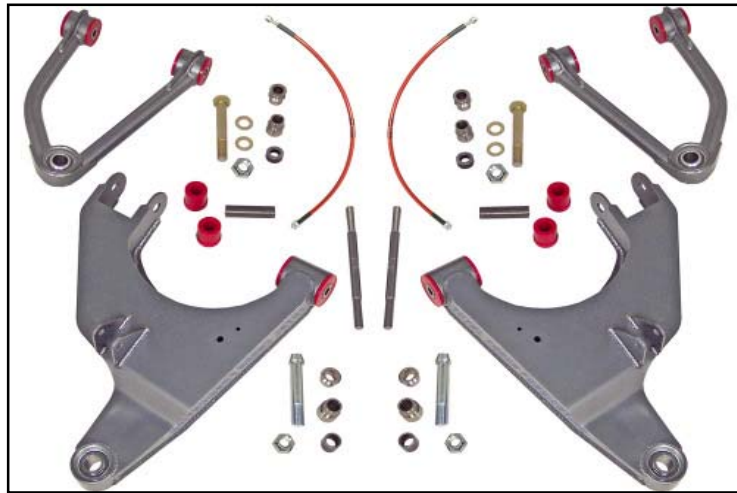

**MSRP: \$2540.00**

**TRAVEL: 12"    LIFT: 3-4"    TIRE: 33x10.5    TRACK INCREASE: 6"    KIT INSTALL: 10hrs**

### Additional Items Required for Installation:

COILOVER SHOCKS, FIBERGLASS FENDERS, UPPER SHOCK MOUNTS(TCA-91600), 300M AXLES(TCA-91300).

### Recommended Shock / Spring Set-up:

Shock Specs: 8" travel 2.5" FOX(1), KING(2), or SWAY-A-WAY(3)  
 Spring(6): 18" 3.0 600lb for KING / FOX. 16" 3.0 600lb for S-A-W.

### Applications Note:

Suspension travel varies on every vehicle. Cutting and welding are required to install kit.  
 To retain 4wd, custom 300M extended axles (TCA-91300) must be installed into factory inner & outer CV joints.  
**98-01 VEHICLES ALSO REQUIRE 25 SPLINE OUTER CV'S FROM A 01-04 VEHICLE.**  
 Spindle modification necessary: drilling upper balljoint hole to 3/4" to mount the upper uniball.  
 This system is a coilover conversion only, kit eliminates torsion bars.

### Accessories / Upgrades:

<b>TCA-49144:</b> Progressive add-a-leaf kit	MSRP: \$190.00
<b>TCA-91099*:</b> Heim steering upgrade(4)	MSRP: \$535.00
<b>TCA-91131:</b> Idler arm brace	MSRP: \$33.74
<b>TCA-91300*:</b> Custom 300M extended axles (pr)	MSRP: \$575.00
<b>TCA-91600:</b> Pre-bent shock hoop for 8" travel 2.5" shock (pr)	MSRP: \$250.00
<b>TCA-91698:</b> Nissan king kong steering kit(5)	MSRP: \$695.00
<b>3/4" Drill:</b> 3/4" tapered reamer	MSRP: \$55.00
<b>Superlube:</b> Synthetic grease (3 o.z. container)	MSRP: \$12.49

- (1) For FOX 8" travel 2.5", must use shock PT#980-99-246B.
- (2) For KING 8" travel 2.5", shock must have 90 degree fitting coming out of the shock to the remote reservoir.
- (3) For S-A-W 8" travel 2.5", must use shock PT#56000-108 & PT#56107-100.
- (4) Heim steering upgrade requires installation on PT#TCA-91698(steering kit).
- (5) Pitman arm core charge of \$75.00 must be applied. PT#91131 Idler Arm Brace is included with King Kong Steering.
- (6) All shock require the use of a tapered cone style bottom coil seat.



**TCS-91500**

**FRONTIER U.C.A.**

2005-2008 NISSAN FRONTIER / XTERRA / PATHFINDER

**Kit Includes:**

- UPPER A-ARMS W/ BUSHINGS
- 1" UNIBALLS W/ RETAINING CLIPS
- GRADE 8 HARDWARE
- GREASE FITTINGS
- TAPERED SPINDLE ADAPTERS
- URETHANE DROOP STOPS



**MSRP: \$710.00**



Fox 2.0" Coilover Package



Icon Vehicle Dynamics 2.5" Coilover Package

**MSRP: \$1,799.00**

**MSRP: Call**

**TRAVEL: 6.5"(1)**

**LIFT: 0-3.25"(2)**

**TIRE: (3)**

**Kit Install: 2hrs**

**Recommended Shock Set-up:**

Aftermarket coil spacer or coilover shock.

**Applications Note:**

- U.C.A. kit is 100% bolt on and requires no permanent modifications.
- U.C.A. kit can be used with any other aftermarket lifts that retain factory upper a-arm.

**Accessories / Upgrades:**

**Superlube:** Synthetic grease (3 o.z. container) MSRP: \$12.49

- (1) U.C.A. allows for 1.75" more droop wheel travel.
- (2) Lift is determined by installation of aftermarket coil spacer or coilover shock
- (3) Tire size will be determined by amount of lift gained from aftermarket lift or coil spacer.



## TCS-92100

## 2WD TOYOTA BALL JOINT KIT

## TCS-92100H

1984-1995 TOYOTA 2WD

### Kit Includes:

- UPPER A-ARMS W/ BUSHINGS
- LOWER A-ARMS W/ BUSHINGS
- STRUT FRAME
- CHROMOLY TIE RODS
- D.O.T. BRAIDED BRAKE LINES
- WELD-ON DROOP STOPS
- 3/4" CHROMOLY ROD ENDS
- URETHANE BUMP STOPS
- GRADE 8 HARDWARE

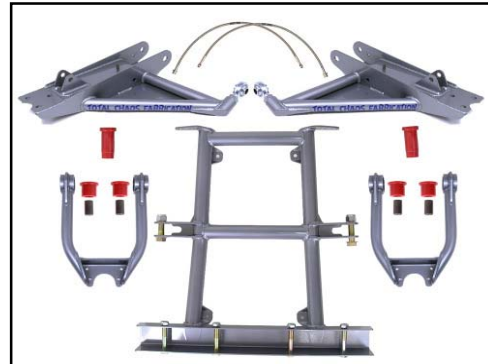

## TCS-92100

## TCS-92100H HEIM STEERING INCLUDED

**MSRP: \$2160.00**

**MSRP: \$2430.00**

**TRAVEL: 11.5"    LIFT: 3-4"    TIRE: 31x10.5(1)    TRACK INCREASE: 6"    KIT INSTALL: 10hrs**

### Additional Items Required For Installation:

SHOCKS & TORSION BARS / or COILOVER SHOCKS, UPPER SHOCK MOUNTS, FIBERGLASS FENDERS, BILLET CROSS SHAFTS(TCA-92420)

### Recommended Shock / Spring Set-up:

Shock Specs: Single 8" or 10"(2) travel 2.5" KING, FOX(1), S-A-W, or BILSTEIN, or Dual 8" or 10" travel 2.0".  
 Torsion Bar: Use S-A-W 25mm / 26mm.  
 Coil Spring: 450lb-500lb spring rate.

### Applications Note:

Some aftermarket balljoints cycle more than stock. Lift varies on each vehicles set-up. Travel varies on every vehicle. 84-88 trucks require 89-95 Toyota lower balljoints, & may require a body lift to run a 31" tire. V-6 must be specified, strut frames differ. 4cyl strut frame comes standard. Custom upper shock mounts must be fabricated.

### Accessories / Upgrades:

<b>TCA-92400:</b> 22R / 22RE Solid motor & transmission mount kit	MSRP: \$433.20
<b>TCA-92420:</b> Billet cross shafts ( highly recommended )	MSRP: \$355.00
<b>TCA-92688*:</b> King kong steering system / 84-88	MSRP: \$1065.90
<b>TCA-92695*:</b> King kong steering system / 89-95 no power steering	MSRP: \$1065.90
<b>TCA-92695P*:</b> King kong steering system / 89-95 w/ power steering	MSRP: \$1065.90
<b>TCA-60921-NYL:</b> Complete nylatron bushing kit	MSRP: \$190.00
<b>TCA-92010:</b> Weld-on dual 2.0" x 10" travel shock tower kit	MSRP: \$171.00
<b>TCA-92008:</b> Weld-on dual 2.0" x 8" travel shock tower kit	MSRP: \$171.00
<b>Superlube:</b> Synthetic grease (3 o.z. container)	MSRP: \$12.49

- (1) Fox 2.5" shocks require 1.25" spacers.
- (2) 10" travel coilover shock will not fit on trucks with V6 engine



**TCS-92200\***

## 2WD TOYOTA UNIBALL KIT

1984-1995 TOYOTA 2WD

**Kit Includes:**

UPPER A-ARMS W/ BUSHINGS	D.O.T. BRAIDED BRAKE LINES	3.5" LIFT SPINDLES(1)(8)
LOWER A-ARMS W/ BUSHINGS	(4) 1" UNIBALLS & RETAINING CLIPS	CHROMOLY TIE RODS
STRUT FRAME	(4) 3/4" CHROMOLY ROD ENDS	GRADE 8 HARDWARE

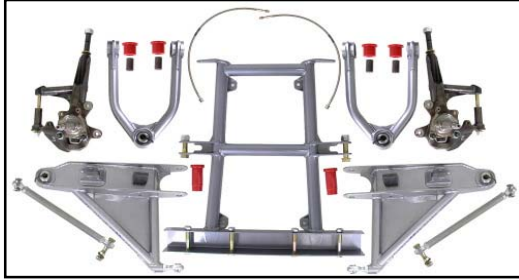

**TCS-92200** 5 LUG SPINDLE KIT

**MSRP: \$3499.00**

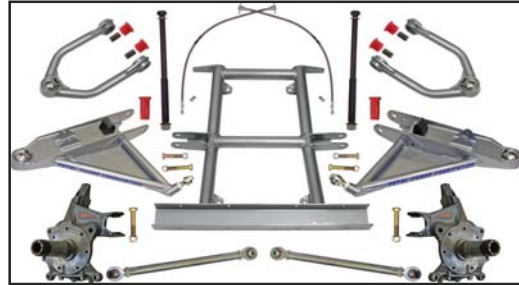

**TCS-92204** 6 LUG SPINDLE KIT

**MSRP: \$3599.00**

<b>TRAVEL: 13.5"</b>	<b>LIFT: 4-6"</b>	<b>TIRE: 33x10.5(2)(3)</b>	<b>TRACK INCREASE: 7"</b>	<b>KIT INSTALL: 11hrs</b>
----------------------	-------------------	----------------------------	---------------------------	---------------------------

**Additional Items Required For Installation:**

SHOCKS & TORSION BARS / or COILOVER SHOCKS, UPPER SHOCK MOUNTS, FIBERGLASS FENDERS, BILLET CROSS SHAFTS(TCA-92420)

**Recommended Shock / Spring Set-up:**

Shock Specs: Single 10"(7) travel 2.5" KING, FOX(4), S-A-W, or BILSTEIN, or Dual 10" travel 2.0".  
 Torsion: Use S-A-W(5) 25mm / 26mm.  
 Coil Spring: 500lb-700lb spring rate (6)

**Applications Note:**

Lift varies on each vehicles set-up. Drilling, welding, and cutting are required to install kit.  
 Only manufacturer of the 3.5" spindle lift, this design increases the front ground clearance.  
 Custom upper shock mounts are required to install shocks.

**Accessories / Upgrades:**

<b>TCA-92400:</b> 22R / 22RE Solid motor & transmission mount kit	MSRP: \$433.20
<b>TCA-92688*:</b> King kong steering system / 84-88	MSRP: \$1065.90
<b>TCA-92695*:</b> King kong steering system / 89-95 non power steering	MSRP: \$1065.90
<b>TCA-92695P*:</b> King kong steering system / 89-95 w/ power steering	MSRP: \$1065.90
<b>TCA-60921-NYL:</b> Complete nylatron bushing kit	MSRP: \$190.00
<b>Superlube:</b> Synthetic grease (3 o.z. container)	MSRP: \$12.49
<b>TCA-92420:</b> Billet Cross Shafts (Highly Recommended)	MSRP: \$355.00

- (1) Spindle core charge of \$200.00 is required. Core consists of left and right spindle and steering arms.
- (2) 1984-1988 trucks require a 2" body lift to run a 33" tire. Tires rub on bed.
- (3) 1989-1995 trucks require no fender well modifications to run a 33x10.5 tire.
- (4) Fox 2.5" shocks require a 2" long rod end & 1.25" spacers.
- (5) On Sway-A-Way torsion bars use torsion bar PT#1636 for 25mm or PT#31636 for 300M bars.
- (6) Spring rate is determined by driving style, vehicle set-up, and desired lift. For dual rate, contact shock manufacturer.
- (7) 10" travel coilover shock will not fit on trucks with V6 engine
- (8) Stock hubs, calipers & rotors must be purchased in order to run 6 lug spindles.



## TCS-95000

## 4WD TOYOTA CADDY KIT GEN 1

1986-1995 TOYOTA 4WD / 4RUNNER & 1992-1998 4WD T-100

### Kit Includes:

- UPPER A-ARMS W/ BUSHINGS
- LOWER A-ARMS W/ BUSHINGS
- CHROMOLY TIE-RODS
- D.O.T. BRAIDED BRAKE LINES
- URETHANE BUMP STOPS
- WELD-ON DROOP STOPS

### TCS-95000BJ

#### BALLJOINT UPPER

MSRP: \$1925.00

### TCS-95000UB

#### UNIBALL UPPER

MSRP: \$2400.00

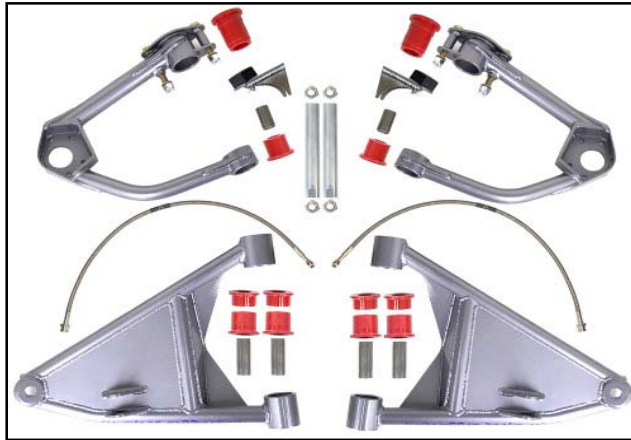

**TRAVEL:** 12"w/4WD(1) **LIFT:** 3-4" **TIRE:** 33" **TRACK INCREASE:** 6.5" **KIT INSTALL:** 8hrs

### Additional Items Required For Installation:

- SHOCKS, TORSION BARS, UPPER SHOCK HOOPS (TCA-95600),
- 4WD T-100 AXLES ON PICKUP / 4RUNNER, 4340 EXTENDED AXLES ON T-100(TCA-95300)
- FIBERGLASS FENDERS

### Recommended Shock / Spring Set-up:

Shock Specs: 10" travel 2.5" KING, BILSTEIN, S-A-W, or 8" travel 2.5" FOX.

Torsion: Use S-A-W 25mm / 27mm or use 300M bars(4)



UNIBALL ARM SHOWN

### Applications Note:

Suspension travel varies on every vehicle. Some aftermarket ball joints cycle more than stock.

Suspension may not cycle full travel by hand until ball joints are broken in.

1986-1988 models MUST upgrade torsion sockets to 1989-1995 V6 torsion sockets.

TCS-95000UB requires drilling of the spindle to a 3/4" hole to mount the uniball.

T-100 trucks require custom 4340 extended axles PT#TCA-95300 that need to be installed into their factory CV joints

Pickup and 4Runner require 4wd T-100 axles to retain 4wd, vehicles can be run as 2wd.

### Accessories / Upgrades:

<b>TCA-95099*</b> : Heim steering upgrade	MSRP: \$489.00
<b>TCA-95130</b> : 4WD "Caddy" idler arm	MSRP: \$370.50
<b>TCA-95140</b> : 1" Lower uniball conversion balljoint	MSRP: \$420.00
<b>TCA-95286 / 95289</b> : Weld-on frame truss	MSRP: \$42.00
<b>TCA-95300*</b> : Custom 4340 extended axles for T-100 trucks	MSRP: \$600.00
<b>TCA-95400</b> : 22R/22RE Solid motor & transmission mounts w/ trans crossmember	MSRP: \$925.00
<b>TCA-95600</b> : Gen 1 shock hoop for single 10" travel 2.5"(2)	MSRP: \$199.50
<b>TCA-95695*</b> : "Caddy" 4WD King Kong Steering Kit(3)	MSRP: \$675.00
<b>3/4" Drill</b> : 3/4" tapered reamer	MSRP: \$55.00
<b>Superlube</b> : Synthetic grease (3 o.z. container)	MSRP: \$12.49
<b>TCA-69500-NYL</b> : Complete nylatron bushing kit	MSRP: \$265.00

(1) Trucks that run kit as 2wd will achieve 13.5" of wheel travel.

(2) For TCA-95600 running FOX shocks, must use 8" travel 2.5" w/ 3"long rod end & 1.25" spacers.

(3) For TCA-95695 use of heim steering upgrade and 4WD "Caddy" idler arm is required

(4) On Sway-A-Way torsion bars use torsion bar PT#1646 for 25mm or PT#31646 for 300M bars.



## TCS-95200

## 4WD TOYOTA CADDY KIT GEN 2

1986-1995 TOYOTA 4WD / 4RUNNER & 1992-1998 4WD T-100

### Kit Includes:

UPPER A-ARMS W/ BUSHINGS

1" UNIBALLS W/ RETAINING CLIPS

LOWER A-ARMS W/ BUSHINGS

CHROMOLY TIE RODS

D.O.T. BRAIDED BRAKE LINES

WELD-ON DROOP STOPS

URETHANE BUMP STOPS

GRADE 8 HARDWARE

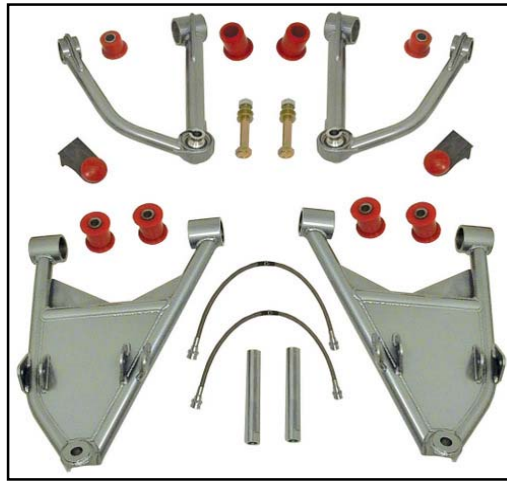

**MSRP: \$2020.00**

**TRAVEL: 12"w/4WD(1) LIFT: 3-4" TIRE: 33" TRACK INCREASE: 6.5" KIT INSTALL: 8hrs**

### Additional Items Required For Installation:

COILOVER SHOCKS, 4WD T-100 AXLES ON PICKUP / 4RUNNER, CUSTOM 4340 AXLES ON T-100(TCA-95300)  
FIBERGLASS FENDERS, UPPER SHOCK MOUNTS(TCA-95602).

### Recommended Shock / Spring Set-up:

Shock Specs: Primary 8" travel 2.5" FOX(2), KING or S-A-W(3). Secondary(4) 8" travel 2.5" non coilover or bypass.  
Coil Spring(5): 18" 3.0 600lb for KING / FOX. 16" 3.0 600lb for S-A-W.

### Applications Note:

Suspension travel varies on every vehicle. Some aftermarket ball joints cycle more than stock.

Drilling of the spindle to 3/4" hole is required to mount the uniball.

T-100 trucks require custom 4340 extended axles PT#TCA-95300 that need to be installed into their factory CV joints.

Pickup and 4Runner require 4wd T-100 axles to retain 4WD, vehicles can be run as 2WD.

### Accessories / Upgrades:

<b>TCA-95099*</b> : Heim steering upgrade	MSRP: \$489.00
<b>TCA-95130</b> : 4WD "Caddy" idler arm	MSRP: \$370.50
<b>TCA-95140</b> : 1" Lower uniball conversion balljoint	MSRP: \$420.00
<b>TCA-95286 / 95289</b> : Weld-on frame truss	MSRP: \$42.00
<b>TCA-95300*</b> : Custom 4340 extended axles for T-100 trucks	MSRP: \$600.00
<b>TCA-95400</b> : 22R/22RE Solid motor & transmission mounts w/ trans crossmember	MSRP: \$925.00
<b>TCA-95602</b> : Gen 2 shock hoop for single or dual 8" travel 2.5" shocks(3)	MSRP: \$285.00
<b>TCA-95695*</b> : "Caddy" 4WD King Kong Steering Kit(6)	MSRP: \$675.00
<b>3/4" Drill</b> : 3/4" tapered reamer	MSRP: \$55.00
<b>TCA-69500-NYL</b> : Complete nylatron bushing kit	MSRP: \$265.00

(1) Trucks that run kit as 2WD will achieve 13.5" of wheel travel.

(2) For FOX 8" travel 2.5", must use shock PT#980-99-246B.

(3) For S-A-W 8" travel 2.5", must use PT#56000-108 & PT#56107-100. Gen 2 shock hoop must be shortened by 1 1/4".

(4) For FOX secondary 8" travel 2.5" shock, all shocks must have 2" long rod end & 1.25" spacers.

(5) All shocks require a tapered cone style lower coil seat to clear 4WD axles.

(6) For TCA-95695 use of heim steering upgrade and 4WD "Caddy" idler arm is required. Core charge is \$125 for pitman arm.



**TCS-95301**

**GEN 3 CADDY KIT (DOES NOT RETAIN 4WD)**

1986-1995 TOYOTA 4WD / 4RUNNER & 1992-1998 4WD T-100

**Kit Includes:**

- UPPER A-ARMS W/ BUSHINGS
- 1" UNIBALLS W/ RETAINING CLIPS
- LOWER A-ARMS W/ BUSHINGS
- CHROMOLY HEIM JOINT TIE RODS
- TEFLON LINED CHROMOLY HEIMS
- HEAT TREATED 17-4 HI-MIS SPACERS
- D.O.T. BRAIDED BRAKE LINES
- GRADE 8 HARDWARE
- TC SIGNATURE 4" LIFT SPINDLES (1)

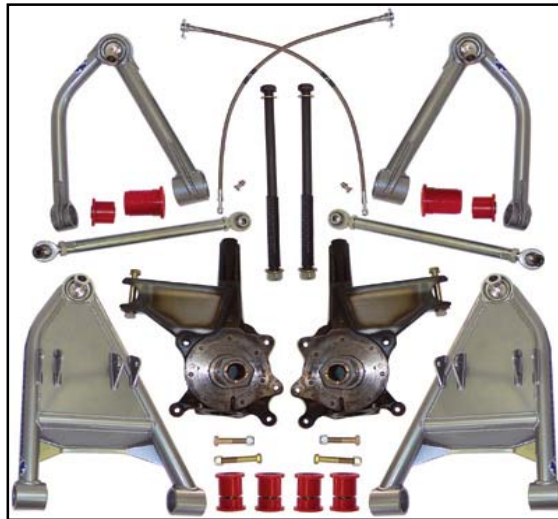

**MSRP: \$3200.00**

**TRAVEL: 15"    LIFT: 5-6"    TIRE: 33" OR 35"    TRACK INCREASE: 10"    KIT INSTALL: 15+hrs**

**Additional Items Required For Installation:**

COILOVER SHOCKS, SECONDARY SHOCKS, AIRBUMPS  
 FIBERGLASS FENDERS, CUSTOM UPPER SHOCK MOUNTS (2)

**Recommended Shock / Spring Set-up:**

Shock Specs: Primary 10" travel 2.5" FOX, KING or S-A-W. Secondary 10" travel 2.5" non coilover or bypass.  
 Short lower rod end recommended for upper shock mount clearance with brake booster.  
 Coil Spring(3): 500LB OVER 500LB 4CYL, 500LB OVER 600LB V6

**Applications Note:**

This kit is designed for the 4wd chassis but does not retain the 4wd capability (no axles, cv's, front diff)  
 Air Bumps can be mounted to strike the spindle thru-bolt, and must be integrated into the engine cage.  
 This kit is not recommended for street legal vehicles.

**Accessories / Upgrades:**

<b>TCA-95695*</b> : "Caddy" 4WD King Kong Steering Kit(4)	MSRP: \$675.00
<b>TCA-95130</b> : 4WD "Caddy" idler arm	MSRP: \$370.50
<b>TCA-95286 / 95289</b> : Weld-on frame truss	MSRP: \$42.00
<b>Superlube</b> : Synthetic grease (3 o.z. container)	MSRP: \$12.49
<b>TCA-69500NYL</b> : Nylatron Bushing and Endwasher Kit	MSRP: \$265.00
<b>TCA-95400</b> : 22R/22RE Solid motor & transmission mounts w/ trans crossmember	MSRP: \$925.00

- (1) Core charge of \$200 for spindles must be applied to every system.
- (2) Shock mounts should be integrated into the vehicles engine cage.
- (3) Spring rates are a baseline recommendation only, each individual truck, driving style, and vehicle setup is different.
- (4) For TCA-95695 use of 4WD "Caddy" idler arm is required, pitman arm core charge of \$125 required.



## TCS-96000

## 4WD / PRERUNNER TACOMA KIT

1996-2004 TOYOTA TACOMA 4WD / PRERUNNER & 1996-2002 4RUNNER (1)

### Kit Includes:

- UPPER A-ARMS W/ BUSHINGS & ZERK FITTINGS
- LOWER A-ARMS W/ BUSHINGS
- TIE-ROD EXTENSIONS
- 1" UNIBALLS & RETAINING CLIPS
- UNIBALL SPINDLE ADAPTER SLUGS
- D.O.T. BRAIDED BRAKE LINES
- BOLT ON UPPER SHOCK MOUNTS(2)
- GRADE 8 HARDWARE
- LIMIT STRAPS W/ ADJUSTERS & MOUNT
- BUMP STOP SPACERS
- PLATED A-ARM END WASHERS
- WELD-ON RESERVOIR MOUNTS

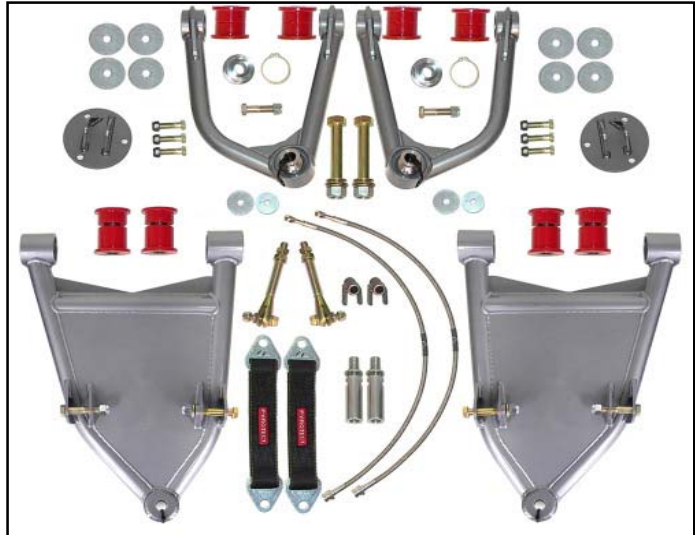

**MSRP: \$2842.00**

**TRAVEL: 13.5"    LIFT: 3-4"    TIRE: 33"    TRACK INCREASE: 7"    KIT INSTALL: 10hrs**

### Additional Items Required For Installation:

SHOCKS, MODIFIED EXTENDED TUNDRA AXLES TO RETAIN 4WD (TCA-96300 / TCA-96400), FIBERGLASS FENDERS

### Recommended Shock / Spring Set-up:

Shock Specs: Primary 8" travel 2.5" FOX(3)(4), KING(5), S-A-W(3). Secondary 8" travel 2.5" FOX(6), KING, SAW.  
 4WD Spring: 18" 3.0 600lb for KING / FOX. 16" 3.0 600lb for S-A-W.  
 2WD Spring: 18" 3.0 500lb for KING / FOX. 16" 3.0 500lb for S-A-W.

### Applications Note:

Suspension travel varies on every vehicle. Welding is required to install the limit strap and reservoir mounts.  
 This kit was not designed to use air bumps.

### Accessories / Upgrades:

<b>TCA-59697:</b> Weld-on spindle gussets	MSRP: \$35.99
<b>TCA-96005:</b> Ball-joint press / slug adapter install tool	MSRP: \$17.25
<b>TCA-96098 / 96099*:</b> 4runner / Tacoma Heim joint tie rod upgrade	MSRP: \$489.00
<b>TCA-96200:</b> 1" front differential drop spacer	MSRP: \$35.99
<b>TCA-96300*:</b> Modified Tundra axles for auto hub	MSRP: \$889.00
<b>TCA-96400*:</b> Modified Tundra axles for manual hub	MSRP: \$1375.00
<b>TCA-96600 / 96601:</b> Secondary shock hoop for dual shock set-up	MSRP: \$235.00
<b>TCA-96701:</b> Tacoma steering rack urethane bushing kit	MSRP: \$25.00
<b>Superlube:</b> Synthetic grease (3 o.z. container)	MSRP: \$12.49

- (1) 96-02 4Runners must be specified when ordering kit, they require different shock mounts and brake lines.
- (2) 8" travel 2.5" FOX or KING use PT# TCS-96000K. 8" travel 2.5" S-A-W use PT# TCS-96000S.
- (3) For FOX 8" travel 2.5", must use PT#980-99-246B. For S-A-W 8" travel 2.5", use PT#56000-108 & PT#56107-100.
- (4) For FOX 8" travel 2.5" with dual shock set-up, additional modifications are required to mount shock reservoirs.
- (5) For KING 8" travel 2.5", shock must have 90 degree fitting coming out of the shock to the remote reservoir.



## TCS-96500

## TACOMA U.C.A

1996-2004 TOYOTA TACOMA 4WD / PRERUNNER & 1996-2002 4RUNNER

## TCS-97500

## TUNDRA U.C.A.

2000-2006 TOYOTA TUNDRA 2WD / 4WD & SEQUOIA

### Kit Includes:

UPPER A-ARMS W/ BUSHINGS  
 PLATED A-ARM END WASHERS  
 1" UNIBALLS & RETAINING CLIPS  
 UNIBALL SPINDLE ADAPTER SLUGS  
 GREASE FITTINGS  
 GRADE 8 HARDWARE



**MSRP: \$745.00**

**TRAVEL:** 8" or 9" w/ Donahoe TCF(1)    **LIFT:** 0-3"(2)(3)    **TIRE:** 33"(4)    **Kit Install:** 2hrs

### Recommended Shock Set-up:

Any aftermarket 2.0" or 2.5" coilover shock. Donahoe Racing TCF specific will allow for 1" of additional droop travel. Aftermarket shocks are not necessary for installation of a-arms.

### Applications Note:

U.C.A. kit can be used with any other aftermarket lift kits that retain factory upper a-arm.

### Accessories / Upgrades:

<b>TCA-49702:</b>	Tundra 3/4" lowering shackles	MSRP: \$189.00
<b>TCA-59697:</b>	Weld-on spindle gussets	MSRP: \$35.99
<b>TCA-96005:</b>	Ball-joint press / slug adapter install tool	MSRP: \$17.25
<b>TCA-96200:</b>	1" front differential drop spacer	MSRP: \$35.99
<b>TCA-96701:</b>	Tacoma / 4Runner steering rack urethane bushing kit	MSRP: \$25.00
<b>TCA-97701:</b>	Tundra / Sequoia steering rack urethane bushing kit	MSRP: \$34.50
<b>Superlube:</b>	Synthetic grease (3 o.z. container)	MSRP: \$12.49

(1) ICON VEHICLE DYNAMICS TCF specific PT#5-8615 will allow for 1" of additional droop travel - 9" total.

(2) Actual lift is determined by installing shock or spacer.

(3) 4wd model trucks require our 1" differential spacer PT# TCA-96200 to maximize lift.

(4) TCA-97500 will clear a 35" tire on 04-06 double-cab Tundras, minor trimming of fender flare required.



**TCS-96504**

**TACOMA / FJ / 4RUNNER U.C.A.**

2005+ TACOMA 4WD / PRERUNNER

2003+ 4RUNNER 2WD / 4WD & 2007+ FJ CRUISER 2WD / 4WD

**Kit Includes:**

- UPPER A-ARMS W/ BUSHINGS
- PLATED END WASHERS
- 1" UNIBALLS W/ RETAINING CLIPS
- GRADE 8 HARDWARE
- GREASE FITTINGS
- TAPERED SPINDLE ADAPTERS



**MSRP: \$686.00**

**TRAVEL:** 8"(1)    **LIFT:** 0-3"(2)    **TIRE:** 285/75R16(3) or 285/70R17(3)    **Kit Install:** 2hrs.

**Recommended Shock Set-up:**

Any aftermarket 2.0 or 2.5 coilover shock. U.C.A. kit is highly recommended with coilover or spacer lift to restore handling.

**Applications Note:**

- Vehicles with 3" of lift will benefit from caster gain of 4 degrees.
- U.C.A. kit is 100% bolt on and requires no permanent modifications.
- U.C.A. kit can be used with any other aftermarket lifts that retain factory upper a-arm.

**Accessories / Upgrades:**

<b>TCA-59698:</b> Weld-on Spindle Gussets	MSRP: \$42.99
<b>TCA-86006:</b> Lower Control Arm Skid Plates	MSRP: \$125.00
<b>TCA-86350:</b> 3.5" Lift Spindles - 05+ Tacoma Prerunner & 2WD FJC/4Runner (pr)	MSRP: \$1399.00
<b>Superlube:</b> Synthetic grease (3 o.z. container)	MSRP: \$12.49

- (1) Suspension travel varies on every vehicle and by brand of shock installed.
- (2) Lift is determined by installation of aftermarket shock or spacer.
- (3) Both 16" & 17" wheels will require 4.5" backspacing.



## TUNDRA LONG TRAVEL KIT

**TCS-97000**

2000-2003 TOYOTA TUNDRA 2WD / 4WD & SEQUOIA

**TCS-97004**

2004-2006 TOYOTA TUNDRA 2WD / 4WD & SEQUOIA

**Kit Includes:**

- UPPER A-ARMS W/ BUSHINGS & ZERK FITTINGS
- LOWER A-ARMS W/ BUSHINGS
- TIE-ROD EXTENSIONS
- 1" UNIBALLS & RETAINING CLIPS
- UNIBALL SPINDLE ADAPTER SLUGS
- D.O.T. BRAIDED BRAKE LINES
- BOLT ON UPPER SHOCK MOUNTS(1)
- GRADE 8 HARDWARE
- LIMIT STRAPS W/ ADJUSTERS & MOUNT
- BUMP STOP SPACERS
- PLATED A-ARM END WASHERS
- WELD-ON RESERVOIR MOUNTS

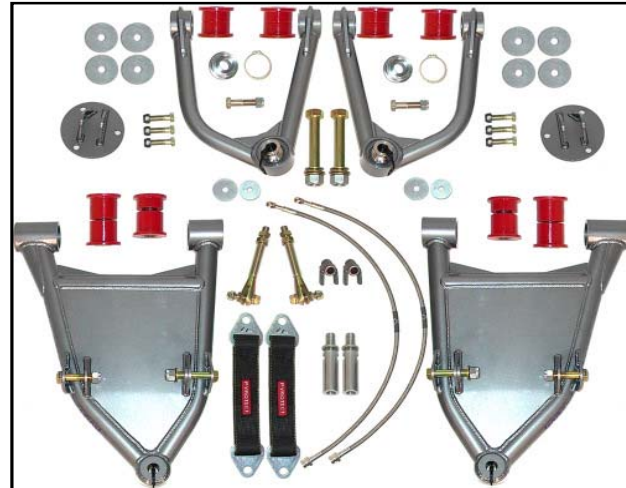

**MSRP: \$2899.00**

**TRAVEL: 13.5" LIFT: 3-4" TIRE: 33" or 35"(2) TRACK INCREASE: 7" KIT INSTALL: 10hrs**

**Additional Items Required For Installation:**

SHOCKS, CUSTOM 4340 EXTENDED AXLE SHAFTS TO RETAIN 4WD( TCA-97300 ), FIBERGLASS FENDERS

**Recommended Shock / Spring Set-up:**

Shock Specs: Primary 8" travel 2.5" FOX(3)(4), KING(5), S-A-W(3). Secondary 8" travel 2.5" FOX(6), KING, SAW.  
 4WD Spring: 18" 3.0 700lb for KING / FOX. 16" 3.0 700lb for S-A-W.  
 2WD Spring: 18" 3.0 600lb for KING / FOX. 16" 3.0 600lb for S-A-W.

**Applications Note:**

2004-2006 trucks require a different lower a-arm and must use PT# **TCS-97004**  
 Suspension travel varies on every vehicle. Welding is required to install the limit strap and reservoir mounts.  
 This kit was not designed to use air bumps.

**Accessories / Upgrades:**

<b>TCA-59697:</b> Weld-on spindle gussets	MSRP: \$35.99
<b>TCA-69700-NYL:</b> Complete nylatron bushing kit	MSRP: \$257.00
<b>TCA-96005:</b> Ball-joint press / slug adapter install tool	MSRP: \$17.25
<b>TCA-96200:</b> 1" front differential drop spacer	MSRP: \$35.99
<b>TCA-97099*:</b> Tundra heim steering upgrade	MSRP: \$489.00
<b>TCA-96600 / 96601:</b> Secondary shock hoop for dual shock set-up	MSRP: \$235.00
<b>TCA-97300*:</b> Custom 4340 extended axles w/ boots	MSRP: \$600.00
<b>TCA-97701:</b> Tundra / Sequoia urethane steering rack mounting kit	MSRP: \$34.50
<b>Superlube:</b> Synthetic grease (3 o.z. container)	MSRP: \$12.49

- (1) 8" travel 2.5" FOX or KING use PT# **TCS-97000K / 97004K**. 8" travel 2.5" S-A-W use PT# **TCS-97000S / 97004S**.
- (2) 35" tires require aftermarket wheels with 4"-5" backspacing to clear upper arm. Minor trimming is required to install.
- (3) For FOX 8" travel 2.5", must use PT#980-99-246B. For S-A-W 8" travel 2.5", use PT#56000-108 & PT#56107-100.
- (4) For FOX 8" travel 2.5" with dual shock set-up, additional modifications are required to mount shock reservoirs.



**TCS-98000**

## TAQUITO LONG TRAVEL KIT

1996-2004 TOYOTA TACOMA 2WD 5-LUG

**Kit Includes:**

- UPPER A-ARMS W/ BUSHINGS
- 1" UNIBALLS W/ RETAINING CLIPS
- LOWER A-ARMS W/ BUSHINGS
- BILLET CHROMOLY CROSS SHAFTS
- CHROMOLY TIE ROD EXTENSIONS
- WELD-ON UPPER COIL BUCKETS
- BOLT ON SHOCK MOUNT PLATES(1)
- D.O.T. BRAIDED BRAKE LINES
- LIMIT STRAPS
- 7/8" CHROMOLY ROD ENDS
- GRADE 8 HARDWARE
- WELD-ON DROOP STOPS
- WELD-ON RESERVOIR MOUNTS

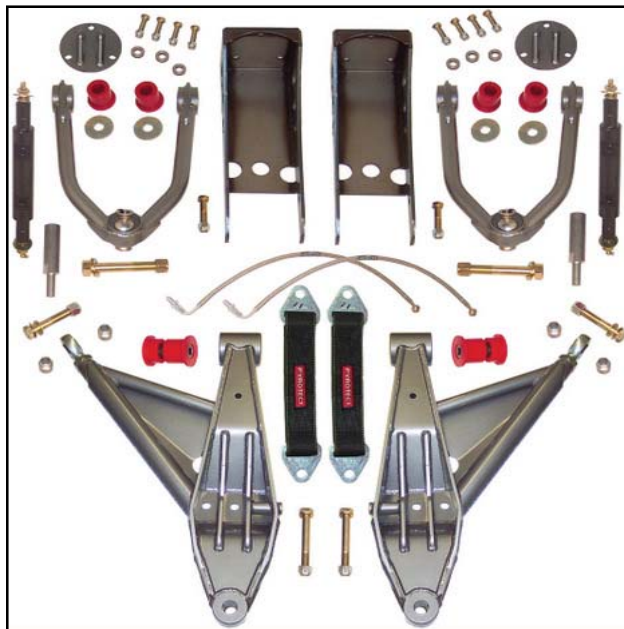

**MSRP: \$2660.00**

**TRAVEL: 11.5"    LIFT: 3-4"    TIRE: 31x10.5    TRACK INCREASE: 7"    KIT INSTALL: 10hrs**

**Additional Items Required For Installation:**

COILOVER SHOCKS, FIBERGLASS FENDERS

**Recommended Shock / Spring Set-up:**

Shock Specs: 8" travel 2.5" FOX(2), KING, or S-A-W.  
 Spring(3): 18" 3.0 450lb-500lb for KING / FOX. 16" 3.0 450lb-500lb for S-A-W.

**Applications Note:**

Suspension travel varies on every vehicle. Cutting & welding are required to mount the coil buckets and droop stops.  
 Drilling of the spindle to a 3/4" hole is required to mount the uniball.  
 LIMIT STRAPS WILL STRETCH. Droop stops are provided with kit and must be installed.

**Accessories / Upgrades:**

<b>TCA-98010:</b> Adjustable limit strap race clevis w/ weld-on mount	MSRP: \$110.00
<b>3/4" Drill:</b> 3/4" tapered reamer	MSRP: \$55.00
<b>Superlube:</b> Synthetic grease (3 o.z. container)	MSRP: \$12.49

- (1) 8" travel 2.5" FOX or KING use PT# TCS-98000K. 8" travel 2.5" S-A-W use PT# TCS-98000S.
- (2) For FOX 8" travel 2.5", must use PT#980-99-246B. For S-A-W 8" travel 2.5", use PT#56000-108 & PT#56107-100.
- (3) All shock require the use of a tapered cone style bottom coil seat.

# ACCESSORIES

## 1984-1995 TOYOTA 2WD

<b>TCA-92099*</b>	<b>HEIM TIE ROD STEERING UPGRADE</b>
-------------------	--------------------------------------

Kit Includes: Application: TCS-92100

- (4) 3/4" Chromoly heims
- (2) 11.5" Chromoly tie rods
- (2) Steering arm gussets (welding required)
- Grade 8 hardware

**MSRP: \$489.00**



<b>TCA-92400</b>	<b>4CYL SOLID ENGINE &amp; TRANSMISSION MOUNT</b>
------------------	---

Kit Includes: Application: 2wd 22R / 22RE

- (2) Solid engine mounts w/ bushings
- (1) Solid transmission mount w/ bushings
- Grade 8 hardware

**MSRP: \$433.20**



<b>TCA-92420</b>	<b>BILLET CROSS SHAFTS</b>
------------------	----------------------------

Kit Includes: Application: Any 84-95 2wd Toyota w/  
aftermarket upper a-arms

- (2) 4130 billet cross shafts
- (4) Plated end washers
- (4) Grease fittings
- Grade 8 hardware

**MSRP: \$355.00**



<b>TCA-92688*</b>	<b>KING KONG STEERING KIT 84-88</b>
-------------------	-------------------------------------

<b>TCA-92695*</b>	<b>KING KONG STEERING KIT 89-95 NON P/S</b>
-------------------	---

<b>TCA-92695P*</b>	<b>KING KONG STEERING KIT 89-95 P/S</b>
--------------------	---

Kit Includes: Application: 84-95 2wd Toyota w/ heim tie rods

- Chromoly idler arm & bracket
- Chromoly center link w/ 3/4" heim
- Chromoly pitman arm
- Grade 8 hardware

**MSRP: \$1065.90**









TCF Inc. will pay \$35 for a pitman arm core if undamaged.

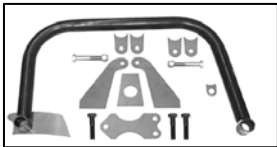

# ACCESSORIES

## 1986-1995 TOYOTA 4WD/4RUNNER & 1992-1998 4WD T-100

<b>TCA-95099*</b>	<b>HEIM TIE ROD STEERING UPGRADE</b>		
<u>Kit Includes:</u> (4) 3/4" Chromoly heim (2) 12.5" Chromoly tie rods (2) Double-shear steering gussets (welding required)		<u>Application:</u> TCS-95000 / 95200 Grade 8 hardware	<b>MSRP: \$489.00</b>
<b>TCA-95130</b>	<b>CADDY IDLER ARM</b>		
<u>Kit Includes:</u> Idler arm Idler arm mount Grade 8 hardware		<u>Application:</u> Any 86-95 Toyota 4wd / 4Runner & 92-98 4wd T-100	<b>MSRP: \$370.50</b>
<b>TCA-95140</b>	<b>1" UNIBALL LOWER BALLJOINT (PAIR)</b>		
<u>Kit Includes:</u> (2) 1" Uniballs (2) Custom 3/4" grade 8 bolts (4) Hi-misalignment spacers (2) 4130 Billet uniball cups		<u>Application:</u> Any 86-95 Toyota 4wd / 4Runner & 92-98 4wd T-100	<b>MSRP: \$420.00</b>
<b>TCA-95286</b>	<b>WELD-ON FRAME TRUSS 86-88</b>		
<b>TCA-95289</b>	<b>WELD-ON FRAME TRUSS 89-95</b>		
<u>Kit Includes:</u> Frame truss		<u>Application:</u> Any 86-95 Toyota 4wd / 4Runner	<b>MSRP: \$42.00</b>
<b>TCA-95300*</b>	<b>CUSTOM 4340 EXTENDED T-100 AXLE SHAFTS</b>		
<u>Kit Includes:</u> (2) 4340 extended axle shafts (2) High angle inner CV boots		<u>Application:</u> T-100 w/ TCS-95000 / 95200	<b>MSRP: \$600.00</b>
<b>TCA-95400</b>	<b>22R/22RE SOLID ENGINE &amp; TRANSMISSION MOUNT W/ X-MEMBER</b>		
<u>Kit Includes:</u> (2) Solid engine mounts w/ bushings (1) Solid transmission mount w/ bushings (1) Transmission crossmember		<u>Application:</u> 4wd 22R / 22RE Grade 8 hardware	<b>MSRP: \$925.00</b>
<b>TCA-95600</b>	<b>WELD ON SHOCK HOOP FOR SINGLE 10" 2.5</b>		
<b>TCA-95602</b>	<b>GEN 2 WELD ON SHOCK HOOP FOR DUAL 8" 2.5</b>		
This will aid in the installation of TCS-95000BJ, TCS-95000UB or TCS-95200		<u>Application:</u> Dual 8" 2.5 FOX(2), KING, or S-A-W 8" 2.5 FOX(1) 10" 2.5 KING, S-A-W, BILSTEIN	<b>TCA-95600 MSRP: \$199.50</b> <b>TCA-95602 MSRP: \$285.00</b>
<u>Kit Includes:</u> Pre bent chromoly hoops Shock tabs for dual shocks Reservoir mounts Chromoly support tubes			
<b>TCA-95695</b>	<b>"CADDY" 4WD KING KONG STEERING KIT</b>		
This kit is highly recommended when installing the Gen. 3 Caddy Kit		<u>Application:</u> TCS-95200 / 95301	<b>MSRP: \$675.00</b>
<u>Kit Includes:</u> Gusseted factory centerlink Gusset factory pitman arm Pitman Arm Core Charge \$125 Vehicle must have heim-joint tie-rods and Caddy Idler Arm			

# ACCESSORIES

2007+ TUNDRA 2WD / 4WD  
 2005+ TACOMA PRERUNNER / 4WD  
 2003+ 4RUNNER 2WD / 4WD  
 2007+ FJ CRUISER 2WD / 4WD

**TCA-49704** | 3/4" LIFT SHACKLE KIT

Kit Includes: (4) 3/8" thick steel shackles  
 14mm hardware  
Application: 2007+ Tundra



**MSRP: \$125.00**

**TCA-87200** | 1" DIFFERENTIAL DROP SPACER

Kit Includes: (2) Plated steel spacers  
 Grade 8 hardware  
Application: 2007+ Tundra

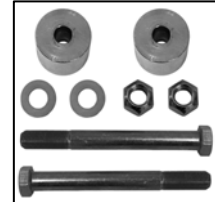

**MSRP: \$35.00**

**TCA-86005** | LOWER CONTROL ARM SKID PLATES

Kit Includes: (2) Bolt-on aluminum skid plates  
 Grade 8 hardware  
Application: TCS-86000 / 86004

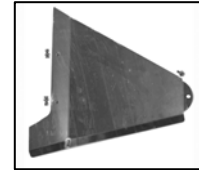

**MSRP: \$112.00**

**TCA-86300\*** | 4340 EXTENDED AXLE SHAFTS FOR 4RUNNER/FJ L/T

**TCA-86301\*** | 4340 EXTENDED AXLE SHAFTS FOR TACOMA L/T

Kit Includes: (2) 4340 extended axle shafts  
Application: TCS-86004/TCS-86000K



**MSRP: \$575.00**

**TCA-86600** | SECONDARY SHOCK HOOPS (FOX / KING)

Kit Includes: (2) Chromoly hoops  
 Shock tabs  
 Grade 8 hardware  
Application: TCS-86000 / 86004  
 For 8" 2.5 secondary shock†



**MSRP: \$250.00**

† FOX 8" travel 2.5" shock must have 2" long rod end & 1.25" spacers.

**TCA-59698** | WELD-ON SPINDLE GUSSET†

Kit Includes: Weld-on spindle gusset (PR)  
Application: TCS-86000 / 86004



**MSRP: \$42.99**

Note: Factory anti-sway bar cannot be used once gussets are installed

\*SPINDLE NOT INCLUDED



# ACCESSORIES

## 2005+ TACOMA PRERUNNER 2003+ 4RUNNER 2WD 2007+ FJ CRUISER 2WD / 4WD

---

<b>TCA-86350</b>	<b>3 1/2" LIFT SPINDLES FOR STOCK SUSPENSION &amp; UCA KITS</b>
<u>Kit Includes:</u> (2) 3.5" Lift spindles	<u>Application:</u> 2005+ Tacoma Prerunner 2003+ 4Runner 2WD 2007+ FJ Cruiser 2WD
<b>MSRP: \$1,399.00</b>	



<b>TCA-86350LT</b>	<b>3 1/2" LIFT SPINDLES FOR LONG TRAVEL KITS</b>
<u>Kit Includes:</u> (2) 3.5" Lift spindles	<u>Application:</u> TCS-86000 / 86004
<b>MSRP: \$1,399.00</b>	



<b>TCA-86006</b>	<b>STOCK LOWER CONTROL ARM SKID PLATES</b>
<u>Kit Includes:</u> (2) Bolt-on steel skid plates Mounting Hardware	<u>Application:</u> 2005+ Tacoma Prerunner / 4WD 2003+ 4Runner 2WD 2007+ FJ Cruiser 2WD
<b>MSRP: \$125.00</b>	



1998-2004 NISSAN FRONTIER 4X2 / 4X4 & XTERRA

**TCA-91131** IDLER ARM BRACE

Kit Includes: Application: 98-04 Frontier 4wd / 4x2 & 99-04 Xterra  
 Idler arm brace

**MSRP: \$42.99**

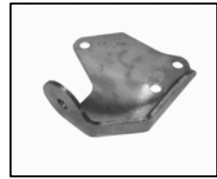

**TCA-49144** PROGRESSIVE ADD-A-LEAF

Kit Includes: Application: 98-04 Frontier 4wd  
 3 leaf add-in pack (PR)

**MSRP: \$190.00**

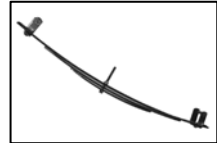

**TCA-91600** WELD ON SHOCK HOOP FOR SINGLE 8" 2.5 COILOVER

Kit Includes: Application: TCS-91420 & TCS-91440  
 Chromoly hoops & support tubes For 8" 2.5 Coilover Shock  
 Shock tabs & grade 8 hardware  
 Reservoir mounts

**MSRP: \$250.00**

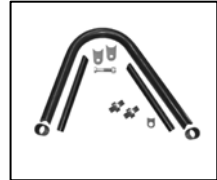

**TCA-91099\*** HEIM TIE ROD STEERING UPGRADE (1)

Kit Includes: Application: 98-04 4wd / 4x2 Frontier & 99-04 Xterra  
 (4) 3/4" Chromoly heims  
 (2) 11.5" Chromoly tie rods  
 Grade 8 hardware

**MSRP: \$535.00**



(1) Heim tie rods also available for stock length arms. Use PT#TCA-91099S.

**TCA-91300\*** CUSTOM 300M EXTENDED AXLES

Kit Includes: Application: TCS-91440  
 (2) 300M extended axle shafts  
**IMPORTANT NOTE: 98-01 VEHICLES REQUIRE 25 SPLINE OUTER CV'S FROM A 01-04 VEHICLE.**

**MSRP: \$575.00**



**TCA-91698 (1)** NISSAN KING KONG STEERING KIT

Kit Includes: Application(2): 98-04 4wd / 4x2 Frontier & 99-04 Xterra  
 Chromoly idler arm  
 Idler arm brace  
 Chromoly centerlink  
 Gusseted pitman arm  
 Grade 8 hardware

**MSRP: \$695.00**











(1) Core charge on pitman arm of \$75.00 is required  
 (2) Installation of TCA-91099 is required to install steering kit



# ACCESSORIES

## 1996-2004 TOYOTA TACOMA 4WD / PRERUNNER / 4RUNNER 2000-2006 TOYOTA TUNDRA 2WD / 4WD & SEQUOIA

<b>TCA-96602</b>	<b>SECONDARY SHOCK HOOP FOR STOCK LOWER CONTROL ARMS</b>	
<p><u>Kit Includes:</u>                      (2) Chromoly hoops                      Shock tabs                      Grade 8 hardware</p>		<p><u>Application:</u> TCS-96500 / 97500                      For 2.0" Secondary Shock                      Fox 6.5": 980-99-023K w/o res.                      Fox 6.5": 980-99-030K w res.                      SAW 6.0": 52000-406 w/o res.                      SAW 6.0": 52000-106 w/ res.                      King 6.0" x 2.0</p>
		<b>MSRP: \$345.00</b>
<b>TCA-96005</b>	<b>BALL JOINT REMOVAL &amp; SLUG INSTALL TOOL</b>	
<p>To aid installation of TCS-96000 / 96500 / 97000 / 97004 / 97500</p>		
		<b>MSRP: \$17.25</b>
<b>TCA-96200</b>	<b>1" DIFFERENTIAL DROP SPACER</b>	
<p><u>Kit Includes:</u>                      (2) Plated steel spacers                      Grade 8 hardware</p>		<p><u>Application:</u> 96-04 Tacoma 6-lug                      96-02 4Runner / 00-06 Tundra</p>
		<b>MSRP: \$35.99</b>
<b>TCA-96300*</b>	<b>MODIFIED AXLES FOR TACOMA L/T (AUTO HUB)</b>	
<p><u>Kit Includes:</u>                      (2) Tundra modified axles w/ CV's &amp; boots</p>		<p><u>Application:</u> TCS-96000 w/ auto hubs</p>
		<b>MSRP: \$889.00</b>
<b>TCA-96400*</b>	<b>MODIFIED AXLES FOR TACOMA L/T (MANUAL HUB)</b>	
<p><u>Kit Includes:</u>                      (2) Tundra modified axles w/ CV's &amp; boots</p>		<p><u>Application:</u> TCS-96000 w/ manual hubs</p>
		<b>MSRP: \$1375.00</b>
<b>TCA-97300*</b>	<b>CUSTOM 4340 EXTENDED AXLE SHAFTS FOR TUNDRA L/T</b>	
<p><u>Kit Includes:</u>                      (2) 4340 extended axle shafts                      (2) High angle inner CV boots</p>		<p><u>Application:</u> TCS-97000 / 97004</p>
		<b>MSRP: \$600.00</b>
<b>TCA-96600</b>	<b>SECONDARY SHOCK HOOP (S-A-W)</b>	
<b>TCA-96601</b>	<b>SECONDARY SHOCK HOOP (FOX &amp; KING)</b>	
<p><u>Kit Includes:</u>                      (2) Chromoly hoops                      Shock tabs                      Grade 8 hardware</p>		<p><u>Application:</u> TCS-96000 / 97000 / 97004                      For 8" 2.5 secondary shock(1)</p>
		<b>MSRP: \$235.00</b>
<b>TCA-96701</b>	<b>TACOMA URETHANE STEERING RACK KIT</b>	
<p><u>Kit Includes:</u>                      (1) D bushing                      (4) Half bushings                      (2) Inner sleeves</p>		<p><u>Application:</u> 96-04 Tacoma 6-lug                      96-02 4Runner</p>
		<b>MSRP: \$25.00</b>

# ACCESSORIES

## 1996-2004 TOYOTA TACOMA 4WD / PRERUNNER / 4RUNNER 2000-2006 TOYOTA TUNDRA 2WD / 4WD & SEQUOIA

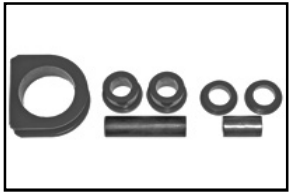
<b>TCA-97701</b>	<b>TUNDRA/SEQUOIA URETHANE STEERING RACK KIT</b>	
<u>Kit Includes:</u> (1) D bushing (4) Half bushings (2) Inner sleeves (1) 5/8" Washer	<u>Application:</u> 00-06 Tundra 01-07 Sequoia	
	<b>MSRP: \$34.50</b>	

<b>TCA-96099*</b>	<b>TACOMA HEIM STEERING UPGRADE</b>	
<u>Kit Includes:</u> (2) 7/8" Chromoly heims w/ jam nuts (2) Chromoly tie rods Double shear tab (welding required) (4) 7/8" - 5/8" Hi-misalignment spacers Grade 8 hardware	<u>Application:</u> 96-04 4wd / Prerunner Tacoma With 3.5" wider arms.	 BALL JOINT NOT INCLUDED
	<b>MSRP: \$489.00</b>	

<b>TCA-96098*</b>	<b>4RUNNER HEIM STEERING UPGRADE</b>	
<u>Kit Includes:</u> (2) 7/8" Chromoly heims w/ jam nuts (2) Chromoly tie rods Double shear tab (welding required) (4) 7/8" - 5/8" Hi-misalignment spacers Grade 8 hardware	<u>Application:</u> 96-02 2wd / 4wd 4Runner With 3.5" wider arms.	 BALL JOINT NOT INCLUDED
	<b>MSRP: \$489.00</b>	

<b>TCA-97099*</b>	<b>TUNDRA HEIM STEERING UPGRADE</b>	
<u>Kit Includes:</u> (2) 7/8" Chromoly heims w/ jam nuts (2) Chromoly tie rods Double shear tab (welding required) (4) 7/8" - 5/8" Hi-misalignment spacers Grade 8 hardware	<u>Application:</u> 00-06 Tundra / Sequoia With 3.5" wider arms.	 BALL JOINT NOT INCLUDED
	<b>MSRP: \$489.00</b>	

<b>TCA-59697</b>	<b>TACOMA / TUNDRA / 4RUNNER SPINDLE GUSSET</b>	
<u>Kit Includes:</u> Weld-on spindle gusset (PR)	<u>Application:</u> 96-04 4wd / Prerunner Tacoma 96-02 4Runner / 00-06 Tundra	 SPINDLE NOT INCLUDED
	<b>MSRP: \$35.99</b>	



# ACCESSORIES

## REAR SUSPENSION COMPONENTS

<b>TCA-40020</b>	<b>U-BOLT BOTTOM SPRING PLATE</b>
------------------	-----------------------------------

Kit Includes: (2) U-bolt plates  
Application: 62" Leaf spring set-up

**MSRP: \$80.00**

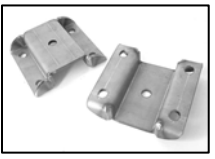

<b>TCA-40060</b>	<b>LEAF SPRING HANGERS- 96-04 TACOMA</b>
------------------	--

<b>TCA-40062</b>	<b>LEAF SPRING HANGERS- 84-95 TOYOTA</b>
------------------	--

Kit Includes: (2) Weld-on hangers  
 Grade 8 hardware  
Application: 62" Leaf spring set-up

**MSRP: \$125.50**



<b>TCA-40900</b>	<b>9" SHACKLE</b>
------------------	-------------------

<b>TCA-41200</b>	<b>12" SHACKLE</b>
------------------	--------------------

Kit Includes: (2) Shackles w/ weld-on sleeve & bushings  
 Grade 8 hardware  
Application: 62" Leaf spring set-up

**MSRP: \$299.00**

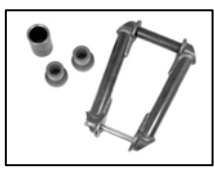

<b>TCA-40450</b>	<b>SHACKLE PIVOT GUSSETS</b>
------------------	------------------------------

Kit Includes: (4) Pre-formed Shackle Gussets  
Application: TCA-40900 & TCA-41200

**MSRP: \$45.50**

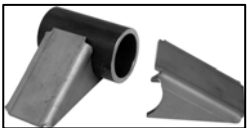

<b>TCA-40080F</b>	<b>FOX (2.5 &amp; 3.0) SHOCK MOUNTS</b>
-------------------	---

<b>TCA-40080S</b>	<b>SWAY-A-WAY / KING / FOX (2.0) SHOCK MOUNTS</b>
-------------------	---

Kit Includes: (2) Shock mounts  
 Grade 8 hardware  
 (4) Spacers  
Application: Rear axle shock mount

**MSRP: \$120.00**



<b>TCA-43326</b>	<b>26" EXTENDED TOYOTA REAR BRAKELINE</b>
------------------	---

Kit Includes: (1) Extended stainless brakeline (D.O.T. approved)  
Application: 84-04 Toyota Pickup & Tacoma

**MSRP: \$65.63**



<b>TCA-48502</b>	<b>F-150 3/4" LOWERING SHACKLE</b>
------------------	------------------------------------

Kit Includes: (2) Shackles  
 (4) Bushings  
 (2) Inner sleeves  
Application: 04-08 4wd F-150

**MSRP: \$199.00**

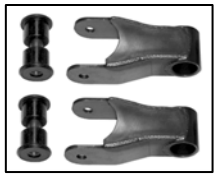

<b>TCA-49504</b>	<b>TITAN 3/4" LOWERING SHACKLE</b>	\$185.00
------------------	------------------------------------	----------

<b>TCA-49702</b>	<b>TUNDRA 3/4" LOWERING SHACKLE</b>	\$189.00
------------------	-------------------------------------	----------

Kit Includes: (2) Shackles  
 (4) Bushings  
 (2) Inner sleeves  
Application: 04-09 Titan 2wd / 4wd  
 04-06 Tundra 2wd / 4wd

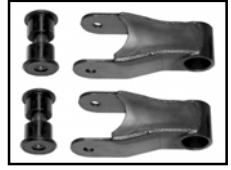

# ACCESSORIES

## REAR SUSPENSION COMPONENTS

<b>TCA-88440</b>	<b>BOLT-ON REAR 62" LEAF SPRING MOUNTING KIT</b>
------------------	--

Kit Includes:  
 (2) Rear shackle mounts  
 (2) U-Bolt spring plates  
 (2) Extended shackles  
 (4) U-Bolts  
 Mounting Hardware

Application: 2005+ Tacoma 2WD 5-Lug

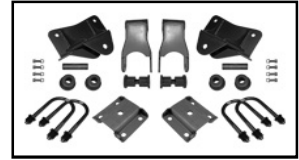

**MSRP: \$1703.00**

## UNIVERSAL COMPONENTS

<b>TCA-40005</b>	<b>SPARE TIRE SPIN ON 5 LUG (5 on 4.5")</b>
<b>TCA-40006</b>	<b>SPARE TIRE SPIN ON 6 LUG (6 on 5.5")</b>
<b>TCA-40007</b>	<b>VW SPARE TIRE SPIN ON (5 on 205mm)</b>

Kit Includes:  
 Tire spin w/ foot  
 Weld on fastening tube

Application: Mount for spare tire



**MSRP: \$191.50**

<b>TCA-30012</b>	<b>SHOCK PIN TO EYELET CONVERSION</b>
------------------	---------------------------------------

Kit Includes:  
 Bolt-on clevis for mounting eyelet shock with 1 1/4" spacing to a pin location (PR)

Application: 90-06 4Runner / 00-06 Tundra  
 Any vehicle with pin mount shocks



**MSRP: \$40.00**

<b>TCA-59204</b>	<b>WELD-ON RESERVOIR TAB</b>
------------------	------------------------------

P/N Includes:  
 (1) Reservoir tab

Application: 2.0" or 2.5" Shock reservoir



**MSRP: \$3.15**

<b>SUPERLUBE</b>	<b>SUPERLUBE SYNTHETIC GREASE</b>
------------------	-----------------------------------

P/N Includes:  
 (1) 3 oz. Tube

Application: Installation & Assembly



**MSRP: \$12.49**



# ACCESSORIES

## REAR SUSPENSION COMPONENTS

**TCA-86440** | BOLT-ON REAR 62" LEAF SPRING MOUNTING KIT

Kit Includes:  
 (2) Rear shackle mounts  
 (2) U-Bolt spring plates  
 (2) Extended shackles  
 Bushings, Inner Sleeves & Mounting Hardware  
Application: 2005+ Tacoma 2WD 5-Lug  
 \*Deaver Leaf Springs (PT# DVR-F67) & U-Bolts must be purchased

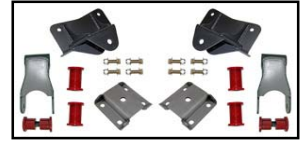

**MSRP: \$659.00**

**TCA-86450** | REAR JOUNCE SHOCK MOUNTING KIT

Kit Includes:  
 (2) Bolt-on Jounce Shock mounts  
 (2) Weld-on Lower bump stop strike pads  
 Mounting Hardware  
Application: 2005+ Tacoma 2WD 5-Lug  
 \*Jounce Shocks must be purchased separately



**MSRP: \$345.00**

**TCA-86460** | REAR DUAL 2.0 SHOCK KIT

Kit Includes:  
 (2) Bolt-on Dual 2.0" Shock Hoops  
 (2) Weld-on Lower shock mounts  
 Mounting Hardware  
Application: 2005+ Tacoma 2WD 5-Lug



**MSRP: \$699.00**

**TCA-86400** | REAR SUSPENSION LINKS

Kit Includes:  
 (2) Upper Links with bushings & grease zerk fittings and 7/8" heim joints Fully Adjustable)  
 (2) Lower Links with bushings & grease zerk fittings and 7/8" heim joints Fully Adjustable)  
 Pan-Hard Bar with 3/4" Heim's (Fully Adjustable)  
 Mounting Hardware & Mis-Alignment Spacers  
Application: 07+ FJ CRUISER/03+ 4RUNNER



**MSRP: \$1289.00**

**TCA-86400** | BOLT-ON REAR SUSPENSION PACKAGE

Kit Includes:  
 DUAL 2.0 SHOCK KIT  
 62" LEAF SPRING MOUNTING KIT  
 JOUNCE SHOCK MOUNTING KIT  
Application: 2005+ Tacoma 2WD 5-Lug  
 \*Deaver Leaf Springs (PT# DVR-F67) & U-Bolts must be purchased

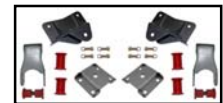

**MSRP: \$1703.00**



## Long Travel Kit Application Guide

Vehicle Model	Year Range	Front Kit Part #	Primary Shock Options	Lift	Wheel Travel	Tire Size	Page #
Tacoma 6lug	1995.5-2004	96000K,S	See Footnotes 1,2,3,8	3"-4"	13.5"	285/75R16 or equivalent	22
	2005+ 2wd	86000K,S	See Footnotes 1,2,3,8	3"-4"	13"	285/75R16 or equivalent	6
	2005+ 4wd	86000K	See Footnotes 8,9	3"-4"	13"	285/75R16 or equivalent	6
Tacoma 5lug	1995.5-2004	98000K,S	See Footnotes 1,2,3,8	3"-4"	11.5"	31x10.5R15	26
	2005+	88000F,S	See Footnotes 1,2,3,8	3"-4"	13"	33x10.5R15	11
Tundra 2wd & 4wd	2000-2003	97000K,S	See Footnotes 1,2,3,8	3"-4"	13.5"	285/75R16 or equivalent	25
	2004-2006	97004K,S	See Footnotes 1,2,3,8	3"-4"	13.5"	285/75R16 or equivalent	25
	2007+	87000K,S		3"-4"	16"	315/75R17	8
4runner 2wd & 4wd	1986-1995	95200	See Footnotes 1,2,3,8	3"-4"	12"	33x10.5R15	20
	1996-2002	96000K-4,S-4	See Footnotes 1,2,3,8	3"-4"	13.5"	285/75R16 or equivalent	22
	2003+	86004	See Footnotes 8,9	3"-4"	13"	285/75R16 or equivalent	6
FJ Cruiser	2007+	86004	See Footnotes 8,9	3"-4"	13"	285/75R16 or equivalent	6
	2007+	86002	See Footnotes 8,9	3"-4"	11.5"	285/75R16 or equivalent	7
4wd Toyota Pickup	1986-1995	95200	See Footnotes 1,2,3,8	3"-4"	12"	33x10.5R15	20
		95301	See Footnotes 7,8	5"-6"	15"	33" or 35"	21
2wd Toyota Pickup	1984-1995	92100	See Footnotes 4,5,6	3"-4"	11"	31x10.5R15	17
		92200, 92204	See Footnotes 4,5,6	4"-6"	13.5"	33x10.5R15	18
Frontier 4x2	1998-2004	91420	See Footnotes 1,2,3,8	4"-6"	13"	285/75R16 or equivalent	14
Frontier 4wd	1998-2004	91440	See Footnotes 1,2,3,8	3"-4"	12"	285/75R16 or equivalent	15
Xterra 2wd	1998-2004	91420	See Footnotes 1,2,3,8	4"-6"	13"	285/75R16 or equivalent	14
Xterra 4wd	1998-2004	91440	See Footnotes 1,2,3,8	3"-4"	12"	285/75R16 or equivalent	15
<b>Footnotes</b>	<b>(1) Fox PT#98099-246B</b>		<b>(2) SAW PT# 56000-108 w/90deg. Fitting</b>		<b>(3) King 8" travel 2.5" dia. coilover w/ 90deg. fitting</b>		
	<b>(4) Dual 2.0 dia. 8" or 10" travel</b>		<b>(5) Single 2.5" 8" or 10" travel</b>		<b>(6) 2.5" coilover, 8" or 10" travel</b>		
	<b>(7) 2.5" Coilover, 10" travel</b>		<b>(8) Shocks require 1.25" wide spacers and tapered lower coil seat</b>				<b>(9) Fox PT#98099-294A</b>
	Due to the variance in extended and collapsed shock length between the manufacturers, an S or K suffix must be applied to most kit part #'s. For Fox or King use a "K" and for Sway A Way use an "S" For example, if you need a kit for an 04 Tundra with King Shocks, the part # would be 97004K						

## Uniball Upper Control Arm Application Guide

Vehicle Model	Year Range	UCA Part #	Shock Options	Lift	Tire Size	Page #
<b>Tacoma 6lug</b>	1995.5-2004	96500	See Footnotes 1,2,3	0"-3"	285/75R16 or equivalent	23
	2005+	96504	See Footnotes 1,2,3	0"-3.5"	285/75R16 or equivalent	24
<b>Tacoma 5lug</b>	2005+	88500	See Footnote 2	0"-3"	31x10.50R15 or equivalent	12
<b>Tundra 2wd &amp; 4wd</b>	2000-2006	97500	See Footnote 1,2,3	0"-2.5"	285/75R16 or equivalent	23
	2007+	87500	See Footnote 1,2	0"-4"	325/65R18 or equivalent	9
<b>4runner 2wd &amp; 4wd</b>	1996-2002	96500	See Footnotes 1,2,3	0"-3"	285/75R16 or equivalent	23
	2003+	96504	See Footnotes 1,2,3	0"-3.5"	285/75R16 or equivalent	24
<b>FJ Cruiser</b>	2007+	96504	See Footnotes 1,2,3	0"-3.5"	285/75R16 or equivalent	24
<b>Landcruiser</b>	2008+	87504	See Footnote 1,2	0"-4"	325/65R18 or equivalent	10
<b>Frontier 2wd &amp; 4wd</b>	2005+	91500	See Footnote 1,4	0"-3"	285/75R16 or equivalent	16
<b>Xterra 2wd &amp; 4wd</b>	2005+	91500	See Footnote 4	0"-3"	285/75R16 or equivalent	16
<b>Titan 2wd &amp; 4wd</b>	2004+	90500	See Footnotes 1,2,4	0"-3"	285/75R16 or equivalent	13
<b>F150</b>	2004+	80501	See Footnotes 1,2,3	0"-3"	285/75R16 or equivalent	5
<b>Silverado/Sierra</b>	2007+	77500	See Footnote 1	0"-2"	TBA	4
<b>Tahoe/Yukon</b>	2007+	77500	See Footnote 1	0"-2"	TBA	4
<b>Footnotes:</b>	<b>(1) Icon Vehicle Dynamics (2) Sway A Way (3) King (4) Fox</b>					